

# C600S Power Package

## Digester Gas



The Signature Series Microturbine provides 600kW of reliable electrical power in one small, ultra-low emission, and highly efficient package.

- + Ultra-low emissions
- + Accepts sour gas fuels with up to 5,000 ppm H<sub>2</sub>S
- + One moving part – minimal maintenance and downtime
- + Patented air bearings – no lubricating oil or coolant
- + Integrated utility synchronization – no external switchgear
- + Compact modular design allows for easy, low-cost installation
- + High electrical efficiency over a very wide operating range
- + High availability – part load redundancy
- + Remote monitoring and diagnostic capabilities
- + Proven technology with tens of millions of operating hours
- + Various Factory Protection Plans available



C600S Power Package

### Electrical Performance<sup>(1)</sup>

Electrical Power Output	600kW
Voltage	400/480 VAC
Electrical Service	3-Phase, 4 Wire Wye
Frequency	50/60 Hz
Electrical Efficiency LHV	33%

### Fuel/Engine Characteristics<sup>(1)</sup>

Digester Gas HHV	20.5–32.6 MJ/m <sup>3</sup> (550–875 BTU/scf)
H <sub>2</sub> S Content	<5,000 ppm
Inlet Pressure	517–551 kPa gauge (75–80 psig)
Fuel Flow HHV	7,200 MJ/hr (6,840,000 BTU/hr)
Net Heat Rate LHV	10.9 MJ/kWh (10,300 BTU/kWh)

### Exhaust Characteristics<sup>(1)</sup>

NO <sub>x</sub> Emissions @ 15% O <sub>2</sub>	< 9 ppmvd (18 mg/m <sup>3</sup> )
Exhaust Mass Flow	4.0 kg/s (8.8 lbm/s)
Exhaust Gas Temperature	280°C (535°F)

### Dimensions & Weight<sup>(2)</sup>

Width x Depth x Height <sup>(3)</sup>	3.0 x 5.8 x 2.9 m (117 x 230 x 114 in)
Weight - Grid Connect Model	11,250 kg (24,800 lbs)
Weight - Dual Mode Model	13,500 kg (29,400 lbs)

Reliable power when and where you need it. Clean and simple.

## Minimum Clearance Requirements<sup>(4)</sup>

Horizontal Clearance	
Left	1.5 m (60 in)
Right	0.0 m (0 in)
Front	1.7 m (65 in)
Rear	2.0 m (80 in)

## Certifications

- UL 2200 Listed
- CE Certified
- Certified to the following grid interconnection standards: UL 1741, VDE, BDEW and CEI 0-16
- Compliant to California Rule 21

## C200 Engine Components

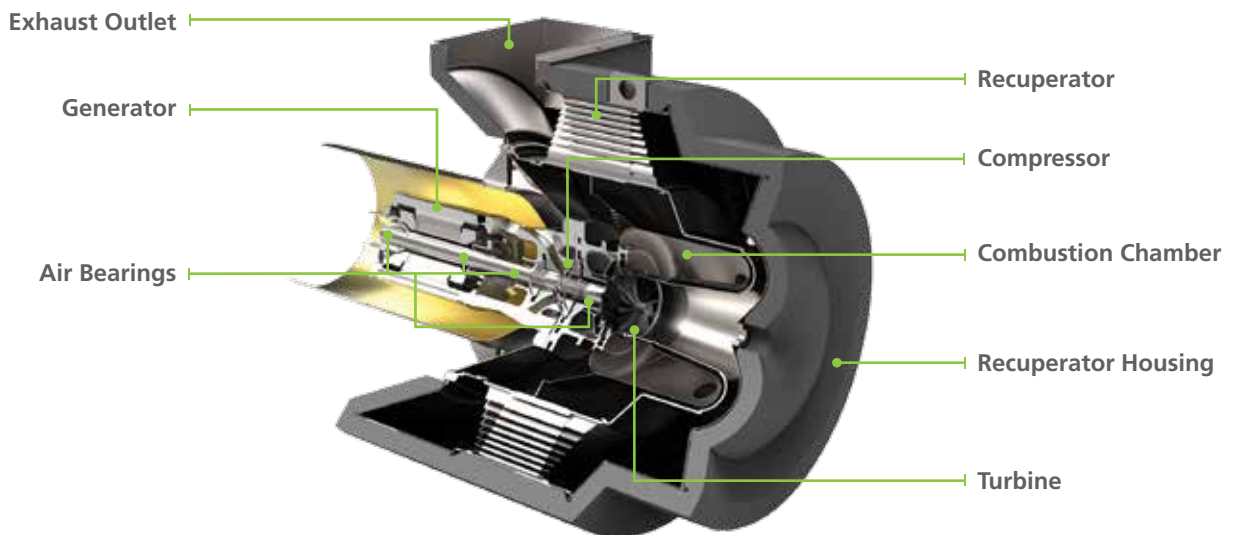

(1) Nominal full power performance at ISO conditions: 15°C (59°F), 14.696 psia, 60% RH  
 (2) Approximate dimensions and weights  
 (3) Height dimensions are to the roofline. Exhaust outlet extends at least 127 mm (5 in) above the roofline  
 (4) Clearance requirements may increase due to local code considerations  
 Specifications are not warranted and are subject to change without notice.

